

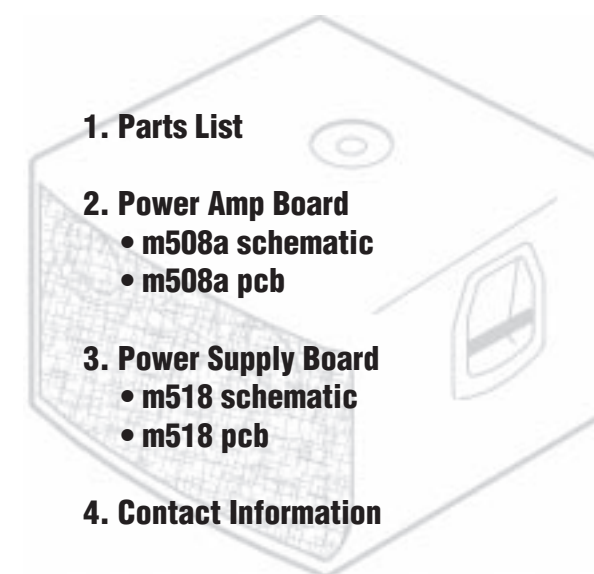

SERVICE MANUAL



ES700P



WEB: www.yorkville.com

WORLD HEADQUARTERS CANADA

Yorkville Sound
550 Granite Court
Pickering, Ontario
L1W-3Y8 CANADA

Voice: (905) 837-8481
Fax: (905) 837-8746

U.S.A.

Yorkville Sound Inc.
4625 Witmer Industrial Estate
Niagara Falls, New York
14305 USA

Voice: (716) 297-2920
Fax: (716) 297-3689



Quality and Innovation Since 1963
Printed in Canada

IMPORTANT SAFETY INSTRUCTIONS



INSTRUCTIONS PERTAINING TO A RISK OF FIRE, ELECTRIC SHOCK, OR INJURY TO PERSONS

INSTRUCTIONS RELATIVES AU RISQUE DE FEU, CHOC ÉLECTRIQUE, OU BLESSURES AUX PERSONNES

CAUTION:

TO REDUCE THE RISK OF ELECTRIC SHOCK, DO NOT REMOVE COVER (OR BACK).

NO USER SERVICEABLE PARTS INSIDE.

REFER SERVICING TO QUALIFIED SERVICE PERSONNEL.

AVIS:

AFIN DE REDUIRE LES RISQUE DE CHOC ELECTRIQUE, N'ENLEVEZ PAS LE COUVERT (OU LE PANNEAU ARRIERE)

NE CONTIENT AUCUNE PIECE REPARABLE PAR L'UTILISATEUR.

CONSULTEZ UN TECHNICIEN QUALIFIE POUR L'ENTRETIEN

Read Instructions

The Owner's Manual should be read and understood before operation of your unit. Please, save these instructions for future reference.

Packaging

Keep the box and packaging materials, in case the unit needs to be returned for service.

Warning

When using electric products, basic precautions should always be followed, including the following:

Power Sources

Your unit should be connected to a power source only of the voltage specified in the owners manual or as marked on the unit. This unit has a polarized plug. Do not use with an extension cord or receptacle unless the plug can be fully inserted. Precautions should be taken so that the grounding scheme on the unit is not defeated.

Hazards

Do not place this product on an unstable cart, stand, tripod, bracket or table. The product may fall, causing serious personal injury and serious damage to the product. Use only with cart, stand, tripod, bracket, or table recommended by the manufacturer or sold with the product. Follow the manufacturer's instructions when installing the product and use mounting accessories recommended by the manufacturer.

The apparatus should not be exposed to dripping or splashing water; no objects filled with liquids should be placed on the apparatus.

Terminals marked with the "lightning bolt" are hazardous live; the external wiring connected to these terminals require installation by an instructed person or the use of ready made leads or cords.

Ensure that proper ventilation is provided around the appliance.

No naked flame sources, such as lighted candles, should be placed on the apparatus.

Power Cord

The AC supply cord should be routed so that it is unlikely that it will be damaged. If the AC supply cord is damaged DO NOT OPERATE THE UNIT.

Service

The unit should be serviced only by qualified service personnel.

Veillez Lire le Manuel

Il contient des informations qui devraient être comprises avant l'opération de votre appareil. Conservez S.V.P. ces instructions pour consultations ultérieures.

Emballage

Conservez la boîte au cas où l'appareil devait être retourner pour réparation.

Attention:

Lors de l'utilisation de produits électrique, assurez-vous d'adhérer à des précautions de bases incluant celle qui suivent:

Alimentation

L'appareil ne doit être branché qu'à une source d'alimentation correspondant au voltage spécifié dans le manuel ou tel qu'indiqué sur l'appareil. Cet appareil est équipé d'une prise d'alimentation polarisée. Ne pas utiliser cet appareil avec un cordon de raccordement à moins qu'il soit possible d'insérer complètement les trois lames. Des précautions doivent être prises afin d'éviter que le système de mise à la terre de l'appareil ne soit désengagé.

Risque

Ne pas placer cet appareil sur un chariot, un support, un trépied ou une table instables. L'appareil pourrait tomber et blesser quelqu'un ou subir des dommages importants. Utiliser seulement un chariot, un support, un trépied ou une table recommandés par le fabricant ou vendus avec le produit. Suivre les instructions du fabricant pour installer l'appareil et utiliser les accessoires recommandés par le fabricant.

Il convient de ne pas placer sur l'appareil de sources de flammes nues, telles que des bougies allumées.

L'appareil ne doit pas être exposé à des égouttements d'eau ou des éclaboussures et qu'aucun objet rempli de liquide tel que des vases ne doit être placé sur l'appareil.

Assurez que l'appareil est fourni de la propre ventilation.

Les dispositifs marqués d'un symbole "d'éclair" sont des parties dangereuses au toucher et que les câblages extérieurs connectés à ces dispositifs de connection extérieure doivent être effectués par un opérateur formé ou en utilisant des cordons déjà préparés.

Cordon d'Alimentation

Évitez d'endommager le cordon d'alimentation. N'UTILISEZ PAS L'APPAREIL si le cordon d'alimentation est endommagé.

Service

Consultez un technicien qualifié pour l'entretien de votre appareil.

ES700P

YS #	Description	Qty.	YS #	Description	Qty.	YS #	Description	Qty.
6410	GREEN 3MM LED 1V7 5MA BULK BRT CLR	1	8661	BUTTON KNOB FLAT GREY	2	8799	#6 X 1/4 PAN PH TYPE B JS500	1
6420	RED 5MM LED 1V7 20MA BRGT SAR5734	2	8693	S ROTARY KNOB GREY	2	8832	6-32 X 1/4 PAN PH TAPTITE SJ500	2
6419	BRIDGE 35A 400V WIRE LEAD GI3504	2	3468	87 3/16 SJT AC LINE CORD STRIP 17"	1	8801	6-32 X 3/8 PAN PH TAPTITE SJ500	2
6425	BAV21 200V 0A25 DIODE T&R	8	3821	HEYCO #1200 STRAIN RELIEF	1	8998	6-32 X 1 FLAT PH MS ZINC CLEAR	4
6438	1N4004 400V 1A0 DIODE T&R	16		"Y" LOGO ELITE SERIES LARGE DOMED	1	8767	#8 X 3/4 PAN PHIL TYPE A SJ500	1
6825	1N4148 75V 0A45 DIODE T&R	28	3521	SIDE ENTRY PCB CONN .156 8POS	1	8785	#8 X 3/4 OVAL PH TYPE A SJ500	4
6479	MUR415 150V 4A0 DIODE FAST RECOV	12	3538	24 PIN BREAKAWAY LOCK .156	0.708	8815	8-32 X 3/4 PAN PH TAPTITE SJ500	12
5121	MZ4615RL 2V0 W25 ZENER 5% T&R	2	3607	SIDE ENTRY PCB CONN. 9 POS.	1	8749	10-32 X 1/2 QDX PH TAPTITE SJ500	2
6440	1N750ARL 4V7 0W5 ZENER 5% T&R	4	3674	9 CIR CABLE HOLDER .098	1	8756	#10 X 3/4 PAN PH TYPE A SJ500	16
6436	1N753ARL 6V2 0W5 ZENER 5% T&R	1	8701	4-40 KEPS NUT ZINC	2	8781	#10 X 7/8 FLAT PHIL TYPE JS500	20
6461	1N5240BRL 10V0 0W5 ZENER 5% T&R	6	8800	6-32 KEPS NUT ZINC	14	8727	#10 X 1" PAN PH MS TYPE AB JS500	16
6450	1N5242B 12V0 0W5 ZENER 5% T&R	2	8797	5/16-18 KEPS NUT SJ500	1	8862	#10 X 1 1/2 PAN PH TYPE A JS500	8
6465	1N5250B 20V0 0W5 ZENER 5% T&R	1	4597	22AWG STRAN TC WIR	9	8751	10-32 X 2 PAN PH MS SJ500	8
6856	NJM7815FA TO220 POS 15V0 REG IS	1	4599	22AWG SOLID SC WIR T&R	29	8777	#14 X 1FLAT PH TYPE A SJ500 M6 HEAD	4
6857	NJM7915FA TO220 NEG 15V0 REG IS	1	5299	22AWG SOLID SC WIR RAD	15	8740	5/16-18 X 3 GRD 5 HEX BOLT SJ500	1
5101	BC550C TO92 NPN TRANS. T&R	10	4745	5.0W 0R1 5% BLK RES	6	3741	.5 SPACER ID-.171 OD-.25 #912-500	6
5102	BC560C TO92 PNP TRANS. T&R	5	4688	1/2W 2R2 5% T&R RES	4	8657	6-32 X 3/8" HEX SPACER ALUMINUM	4
5109	MPSA43 TO92 NPN TRANS.	10	4748	2.0W 3R9 5% BLK RES	2	7269	10" 2R4 SPECIAL 300W CAST FRAME SPK	2
5110	MPSA93 TO92 PNP TRANS.	14	4675	1/2W 10R 5% T&R RES	2	8818	3/4 OD X 5/16 ID X .08 THICK WASHER	1
5119	2N5638 TO92 N CHAN J FETT&R	4	4591	1/8W 22R1 1%FLAME PROOF T&R RES	2	3511	#6 FLAT WASHER NYLON	2
6928	IRFP250 TO247 N CHAN MOSFET	6	4816	1/4W 33R 5% T&R RES	1	8485	#6 SPLIT WASHER ZINC	2
6991	MJL21193 TO3P PNP TRANS PWR	2	4590	1/8W 100R0 1%FLAME PROOF T&R RES	2	8820	#8 FLAT WASHER SJ500	4
6878	TL071CP IC FET OP AMP	1	4921	1/4W 100R 5% .2"U T&R RES	6	8473	#10 BLACK CUPWASHER SWF-10BK	1
6882	TL072CP IC FET DUAL OP AMP	7	4909	1/4W 200R 5% T&R RES	2	3436	DPDT PUSH SW PCMT H BREAK B4 MAKE	1
6745	LM13600N IC XCONDUCTANCE AMP	1	4932	1/4W 200R 5% .2"U T&R RES	8	3587	DPDT ROKR SW QUIK 250" AC/PWR SEMKO	1
6446	MAC15A4FP TO220 15A TRIAC 200V	2	4857	1/4W 220R 5% T&R RES	2	3399	THERMO/BRKR/N/CLOSED OPEN@96C	1
6472	4K7 3% 0W0 THERMISTOR	2	4606	1/8W 249R 2%FLAME PROOF T&R RES	4	3937	YELLOW 18 AWG TR-64 PREFUSED	1
6473	68K 3% 0W0 THERMISTOR	4	4780	1/8W 274R 1%FLAME PROOF T&R RES	4	3939	BLUE 18 AWG TR-64 PREFUSED	1
6482	115R 20% 0W0 PTC THERMISTOR	2	4698	1/8W 475R 1%FLAME PROOF T&R RES	4	3940	RED 18 AWG TR-64 PREFUSED	6.25
5405	27P 200V 5%CAP T&R RAD CER.2"NPO	2	4933	1/4W 470R 5% .2"U T&R RES	2	3941	BLACK 18 AWG TR-64 PREFUSED	6.666
5199	100P 100V 2%CAP T&R RAD CER.2"NPO	4	4781	1/8W 681R 1%FLAME PROOF T&R RES	2	3942	WHITE 18 AWG TR-64 PREFUSED	1
5197	220P 100V 2%CAP T&R RAD CER.2"NPO	2	4923	1/4W 680R 5% .2"U T&R RES	3	3950	GREEN 18 AWG TR-64 PREFUSED	1.125
5201	470P 100V 5%CAP T&R RAD CER.2"NPO	10	4758	1/4W 953R 1% T&R RES	8	3958	BLACK 18AWG 36STND WIRE DOUBLE INS	2.416
5816	680P 100V 5%CAP T&R RAD CER.2"NPO	2	4823	1/4W 1K 5% T&R RES	3	1287	PPW /EPW 120VAC 60HZ T?RD	1
5275	3N3 100V 5%CAP T&R RADIAL.2"FILM	6	4981	1/4W 1K 5%MINI T&R RES	1	8468	VELCRO STRAP 3/4"X18CM (VELSTRAP)	1
5209	4N7 250V 5%CAP T&R RADIAL.2"FILM	2	4625	1/2W 1K8 5% T&R RES	1	8483	ADAPTOR,SPEAKER STAND,METAL,BLACK	1
6451	4N7 250V 20%CAP AC Y ONLY RAD10MM	1	4936	1/4W 2K7 5% .2"U T&R RES	10	8547	PLASTIC FOOT BLACK	4
5204	10N 100V 10%CAP T&R RADIAL.2"FILM	1	4764	1/4W 2K740 0.1% *** T&R RES	2	8567	CORNER, 2 LEGS/1 LIP BLACK OXIDE	4
6435	22N 275V 20%CAP AC X2 RAD BLK15MM	1	4826	1/4W 3K3 5% T&R RES	1	8569	CORNER, 2 LEGS/NO LIP BLACK OXIDE	4
5222	33N 100V 10%CAP T&R RADIAL.2"FILM	1	4943	1/4W 4K7 5% .2"U T&R RES	4			
5224	47N 100V 10%CAP T&R RADIAL.2"FILM	8	4982	1/4W 4K7 5%MINI T&R RES	3			
5228	100N 100V 5%CAP T&R RADIAL.2"FILM	21	4939	1/4W 5K1 5% .2"U T&R RES	2			
5229	150N 63V 10%CAP T&R RADIAL.2"FILM	2	4685	1.0W 5K6 5% T&R RES	2			
5231	220N 63V 10%CAP T&R RADIAL.2"FILM	7	4862	1/4W 5K6 5% T&R RES	8			
5318	220N 50V 10%CAP T&R BEAD X7R	1	4829	1/4W 10K 5% T&R RES	6			
5259	4U7 63V 20%CAP T&R RADIAL ELE.2"	2	4940	1/4W 10K 5% .2"U T&R RES	8			
5281	10U 16V 20%CAP NONPOLAR T&R .2"	4	4983	1/4W 10K 5%MINI T&R RES	7			
5945	10U 63V 20%CAP T&R RADIAL ELECTR	2	4630	1/2W 15K 5% T&R RES	3			
5260	22U 50V 20%CAP T&R RADIAL ELE.2"	6	4885	1/4W 20K 5% T&R RES	4			
5961	33U 16V 20%CAP NONPOLAR T&R RAD	6	6118	1/4W 22K 5%MINI T&R RES	2			
5265	68U 25V 20%CAP T&R RADIAL ELE.2"	4	4941	1/4W 30K 5% .2"U T&R RES	8			
5267	100U 25V 20%CAP T&R RADIAL ELE.2"	3	4917	1/4W 31K6 1% T&R RES	6			
5914	100U 63V 20%CAP RADIAL ELECT BULK	2	4840	1/4W 33K 5% T&R RES	5			
5621	470U 63V 20%CAP RADIAL ELECT BULK	4	6122	1/4W 33K 5%MINI T&R RES	5			
5859	4700U 50V 20%CAP RADIAL ELECT BULK	2	4794	1/4W 37K90 0.1% *** T&R RES	2			
5890	5600U 100V 20%CAP RAD ELECT 35X50MM	4	4878	1/4W 43K 5% T&R RES	2			
4403	10K 5B-LINEAR STYLE"P14"16MM	1	4834	1/4W 47K 5% T&R RES	2			
4389	20K STEREO B2-LIN STYLE"P24"16MM	1	6119	1/4W 47K 5%MINI T&R RES	2			
3819	5UH COIL 18AWG R000 AIR CORE	2	4835	1/4W 56K 5% T&R RES	2			
3489	CLIP 250X032 18-22AWG DISCO/INSL	6	4836	1/4W 68K 5% T&R RES	1			
3490	CLIP 250X032 14-16AWG DISCO/INSL	1	4763	1/4W 82K50 0.1% *** T&R RES	6			
3491	CLIP 205/187X020 18-22AWG DISCO/INS	4	4772	1/4W 82K5 1% T&R RES	4			
3601	RING TERMINAL 16AWG WIRE & #8 SCREW	1	4838	1/4W 100K 5% T&R RES	4			
3682	250 MALE PCB TAB BULK ON CATRIGE	11	6120	1/4W 100K 5%MINI T&R RES	1			
3498	M203-02 PLAIN PC MNT JK SKT	4	4839	1/4W 150K 5% T&R RES	2			
3451	0.089 OD SMALL EYELET ELECTROPLATED	55	4841	1/4W 220K 5% T&R RES	6			
3412	LOWPROFILE FUSEHOLDER 1/4" H345601	1	4844	1/4W 1M 5% T&R RES	4			
3414	INTERNATIONAL PC MOUNT FUSEHOLDER	8	4888	1/4W 4M7 5% T&R RES	1			
2427	5.0 AMP SLO-BLO .25X1.25 FUSE	1	3608	10" 9C-24AWG RIBBON HEAVY DUT.100"	1			
2438	12.0 AMP SLO-BLO .25X1.25 FUSE	4	9010	16GA COLD ROLLED STEEL 4X8? SHEET	0.25			
8536	CAST HANDLE "YORKVILLE" PULSE BLUE	2	9046	.25" HOLE @ .375 STAG 16GA PERFORAT	2.91			
3501	B52200F006 COMP WASH #4 SMALL	2	9065	14GA SATINCOAT STEEL 4X8 SHEET	0.195			
3556	XSISTOR HOLD SPRING-BAR (PLATED)	4	9140	.125" 48X96 UTILITY ALUM W/PLASTIC	0.2			
3800	BELLY BUTTON #BB1 CORDS CANADA	8	9549	.187" 48X96 UTILITY ALUMINUM	2			
3862	SIL PAD 400 1.5X6.75	2	9563	NO RIB HEATSINK #200967	0.792			
9897	CABINET COVER, BLACK, 54" WIDE	20.2	9640	.025" FISHPAPER (FLAT 48? SHEETS)	0.332			
3795	#8 GROUND LUG ZIERICK 505-169	1	9811	3/4"X4?X8? SPRUCE STAN. SHEATING	23.1			
3798	8" NYLON CABLE TIE	2	9815	1/2" POPLAR SELECT 1 4X4 ONLY	1.25			
3803	NYLON SECUR-A-TACH MINI PLASTIC TIE	1	8742	4-40 X 3/8 PAN PH TAPTITE SJ500	16			
3810	4" NYLON CABLE TIE	13	8861	4-40 X 3/8 PAN PH MS SJ500	2			

U:\M508AV16.PRN

A

FET_CNTL
CONNECTED TO M509 MX1

MC2

9 NEG_IN_R
8 POS_IN_R
7 CLIP_R
6 GND
5
4 GND
3 CLIP_L
2 POS_IN_L
1 NEG_IN_L

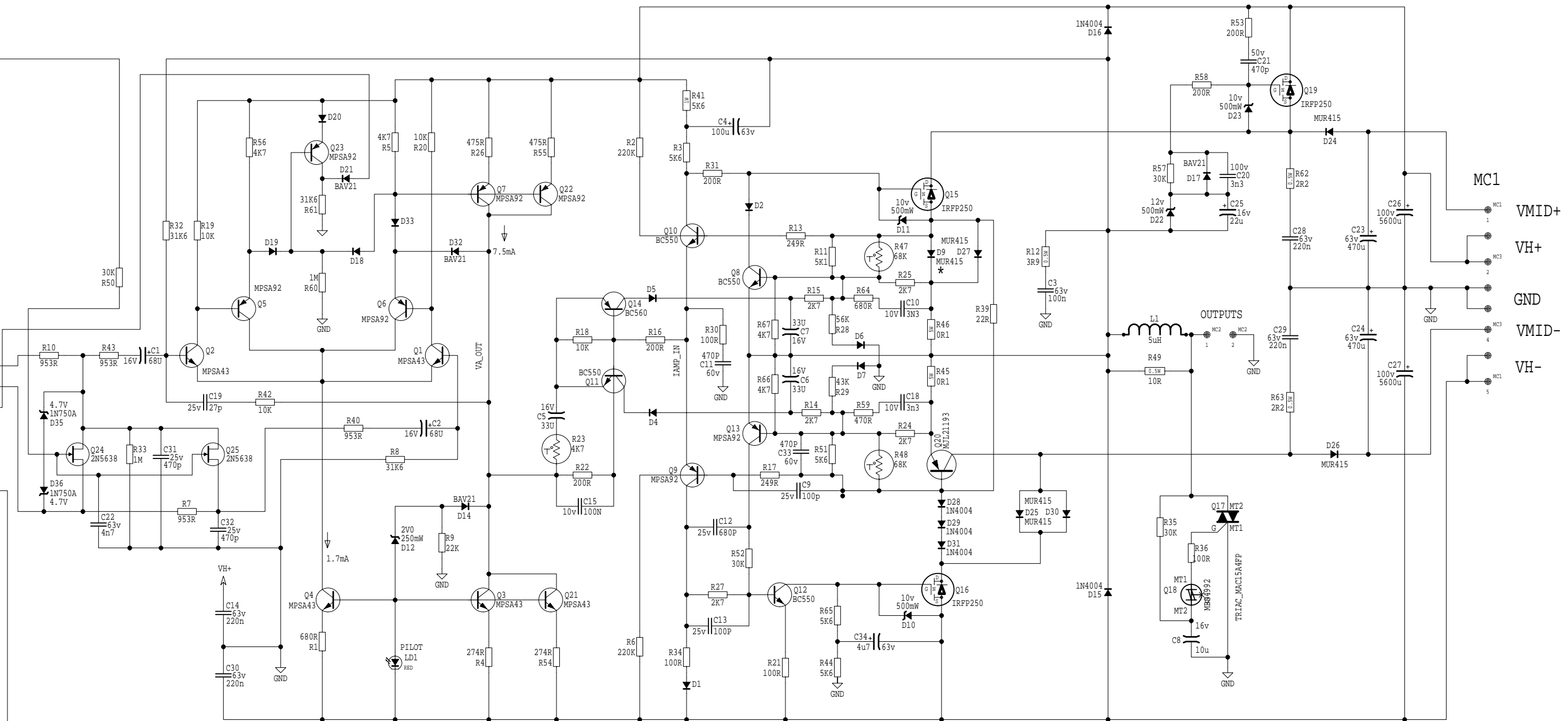

MC1

1 VMID+
2 VH+
3 GND
4 VMID-
5 VH-

SERVICE WARNING: POTENTIALS GREATER THAN 130VDC PRESENT.

USE EXTREME CAUTION.

CLIP_L
POS_IN_L
NEG_IN_L

CONNECTIONS TO
THE LEFT CHAN
AMPLIFIER

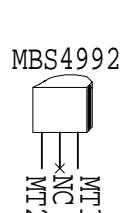
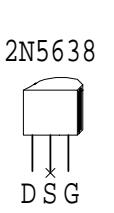
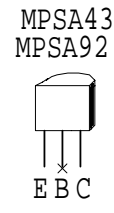
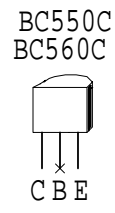
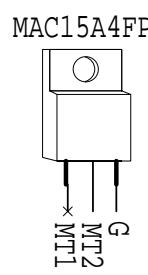
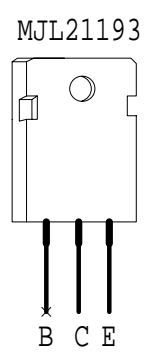
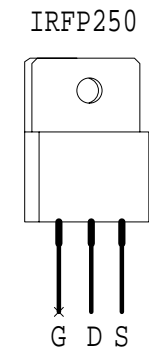

M508A.SCH_DATABASE_HISTORY			
MODEL(S) :- LS700P-PS218P			
#	DATE	VER#	DESCRIPTION OF CHANGE
1	AUG/26/04	1.60	PC#6722_ADD_R66,R67_E->B,Q13,Q8
2	D	V	N
3	D	V	N
4	D	V	N
5	D	V	N
6	D	V	N
7	D	V	N
8	D	V	N
9	D	V	N
10	D	V	N



00.L1-8L2M EDI29EQD102
 ASSEMBLY M518-11.00
 PCB MECH M518-11.00

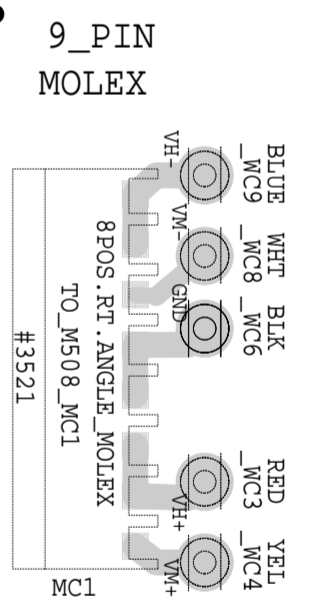
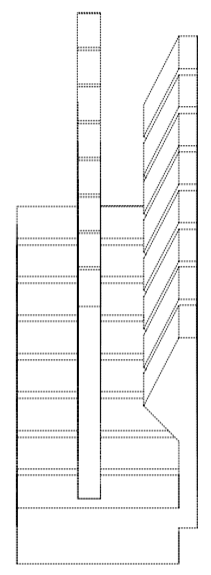
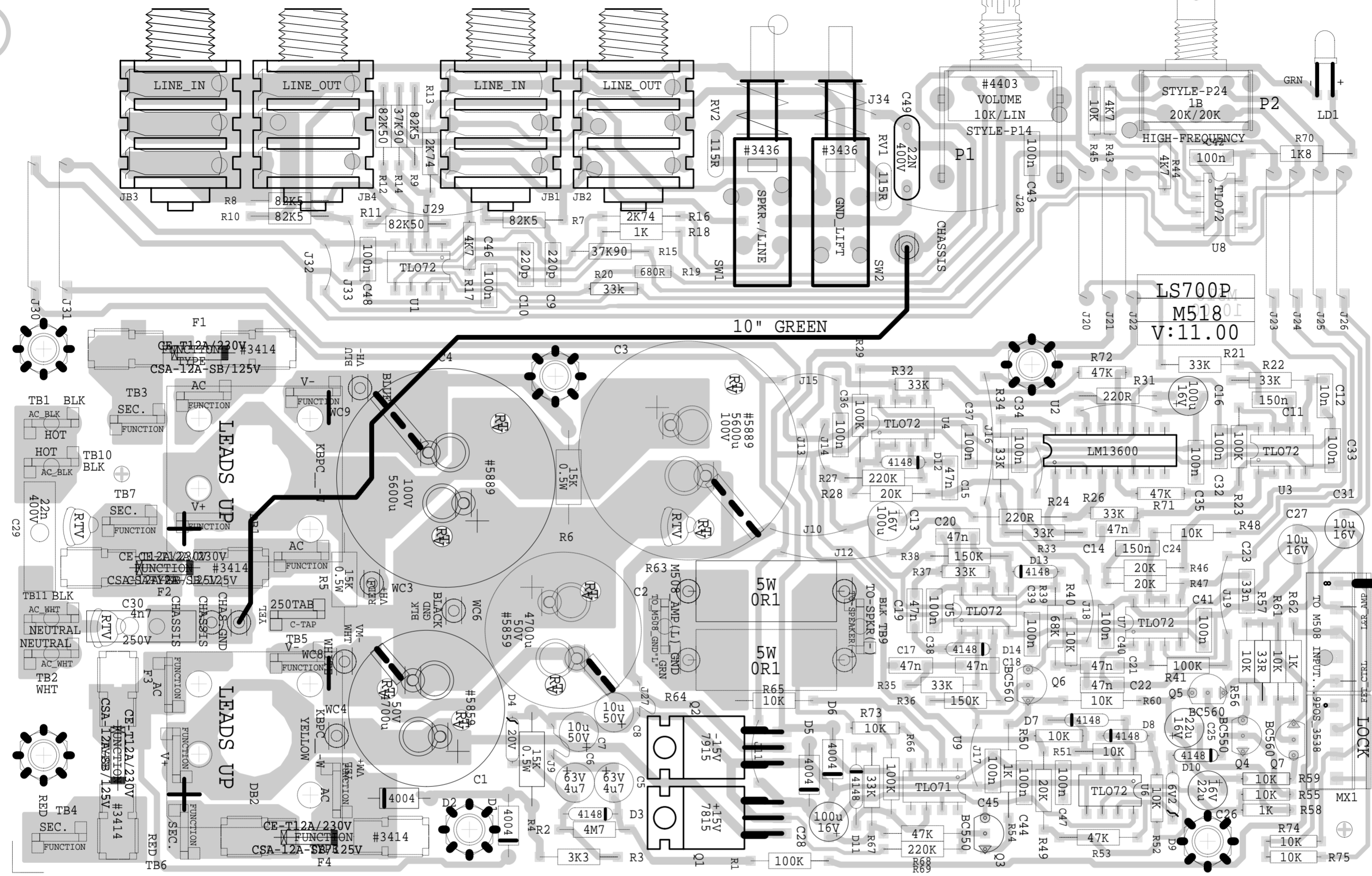

"008.01X" 02S, SL=EN12, MIAL1B
 BLANK SIZE=12.250" X 10.800"

M518.PCB_DATABASE_HISTORY

MODEL(S):- LS700P

#	DATE	VER#	DESCRIPTION OF CHANGE
1	AUG/21/95	1.00	DESIGN BY TOM WOOD
2	AUG/24/95	1.10	PC#4871 R45 4K7-->10K_R11,R12_9K760-->82K50_0.1%
3	.	.	PC#4877 MOVE RTV HOLES FOR C1
4	SEP/01/95	1.20	PC#4885/4886 REPLACE R25,30 WITH JUMPERS ADD 10K IN SERIES WITH
5	SEP/12/95	2.00	PIN 3 U9 ADD 47K IN SERIES WITH PIN 5,12 U2 R65 1K->10K_R66 10K->100K
6	.	.	C27 MOVED FOR CLEARANCE AT MOLEX
7	.	.	
8	.	.	
9	SEP/25/95	2.10	PC#5079 R18 2K74 -> 1K
10	APR/3/96	2.11	PC#5303 C7 MOVED.ROUTING AT JACKS CHGD
11	MAY/20/97	3.00	PC#6130 MOVE R3 AWAY FROM R2
12	OCT/06/99	4.00	PC#6109 REDO GND LIFT SW. ADD C49
13	.	.	ADD EYELET. CHANGE PADS FOR RAD JUMPR
14	DEC/02/99	5.00	NEW PADS FOR TABS AND FUSEHOLDERS
15	APR/18/02	6.00	PC#6413 FIX TRACES AT U5
16	JUL/16/02	7.00	ADD ROUTING NO OTHER CHANGES
17	OCT/23/02	7.10	PC#6573 TABS FOR BRIDGE
18	NOV/14/02	8.00	PC6596 ADD R74, R75
19	APR/04/03	9.00	MOVE FUSEHOLDER AWAY FROM TRACE
20	SEP/02/03	10.00	
21	JUN/16/05	11.00	PC#6905 ADD ROUTGAUGE REDO MASK



M518.PCB_POT_LIST

MODEL(S):- EPW/LS700P

REF	FUNCTION	PART#	KNOB	AS_OF
P1	VOLUME	#4403	#8693	DEC/99
P2	HIGH_FREQ	#4389	#8693	DEC/99
R	F	P	K	N
R	F	P	K	N
R	F	P	K	N
R	F	P	K	N

PRODUCTION NOTES

1 NOTE ORIENTATION OF LOCK ON THE MOLEX FOR MX1

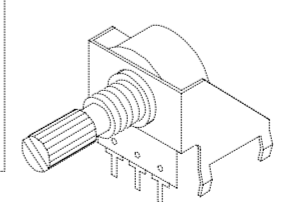

STYLE "P14"

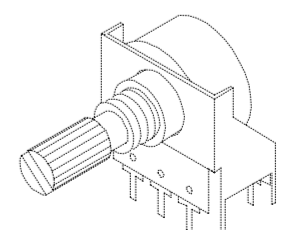

STYLE "P24"